

Electrical rating 20kVA  
3m long device power cord

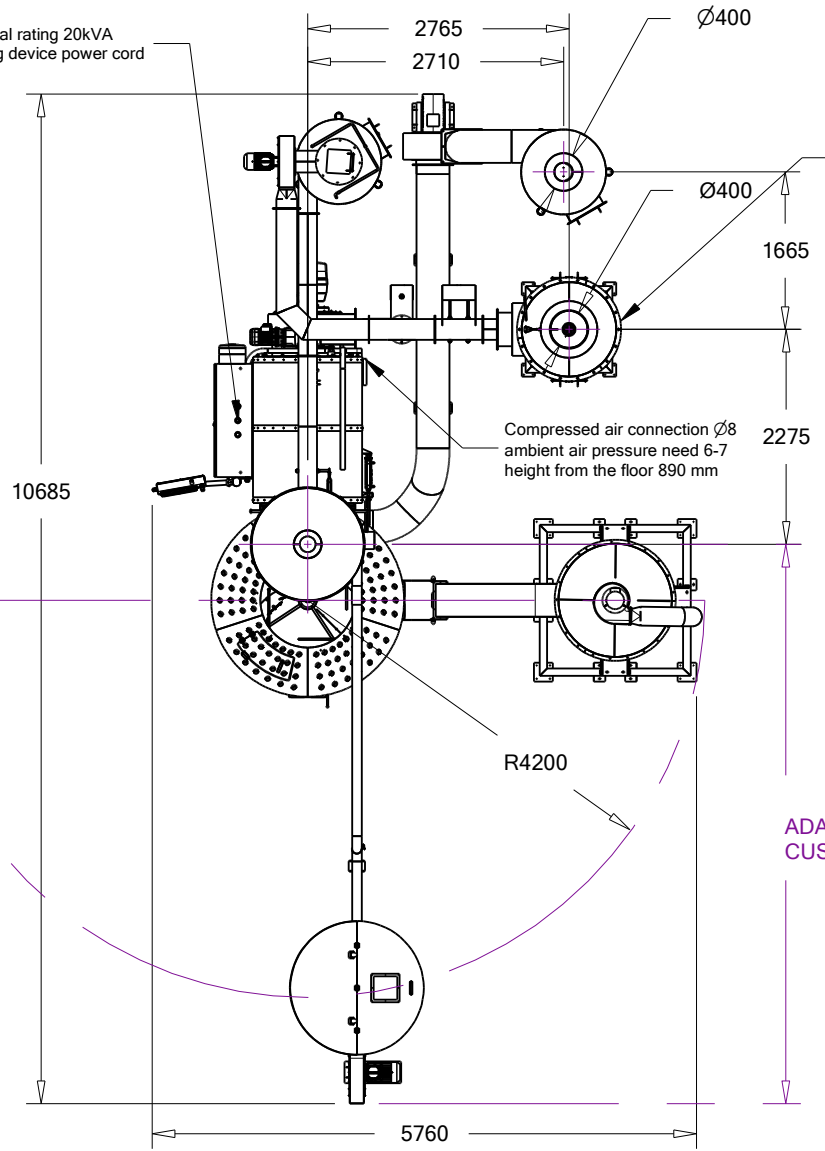

Gas connection G1 1/2"; burner capacity max. 350 kW  
22 mbar flow pressure at full load  
ambient gas need 25 m3/h  
height from the floor 480 mm

Water connection G1/2"  
ambient water pressure need 3 bar  
height from the floor 905 mm

Gas connection G1 1/4"; burner capacity max. 189 kW  
36 mbar flow pressure at full load  
ambient gas need 19 m3/h  
height from the floor 2100 mm

ADAPTED TO  
CUSTOMER REQUIREMENTS

